

REVISIONS				
ZONE	REV.	DESCRIPTION	DATE	APPROVED

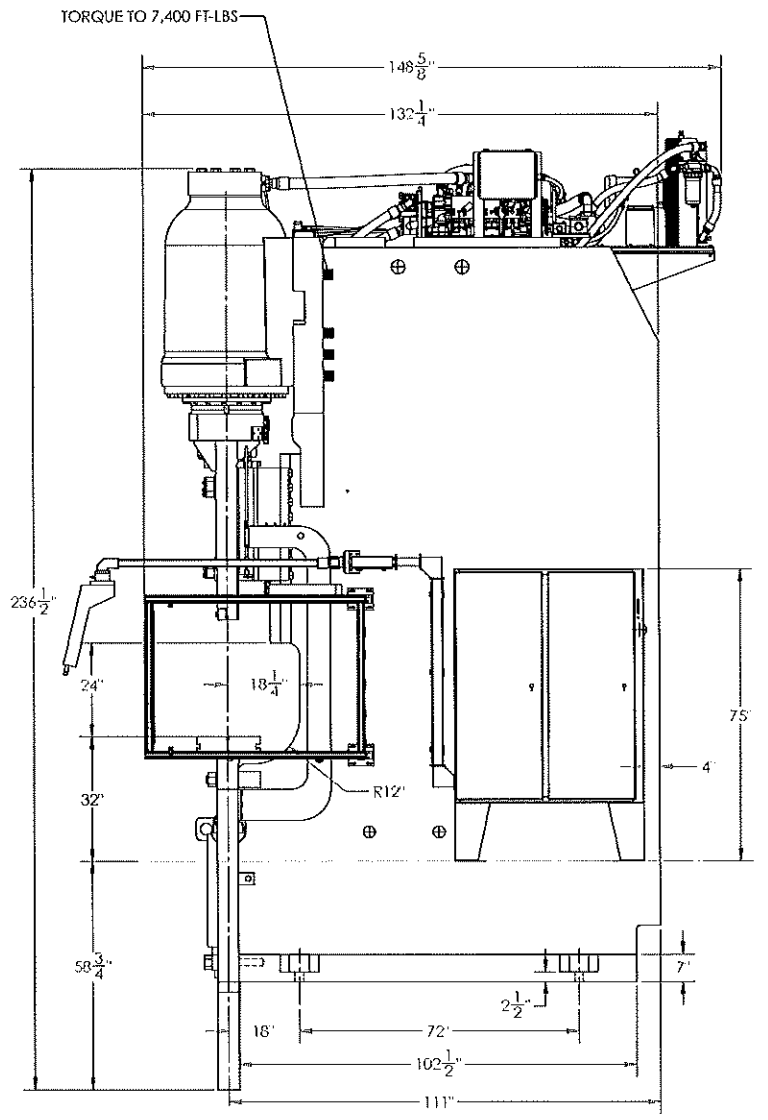
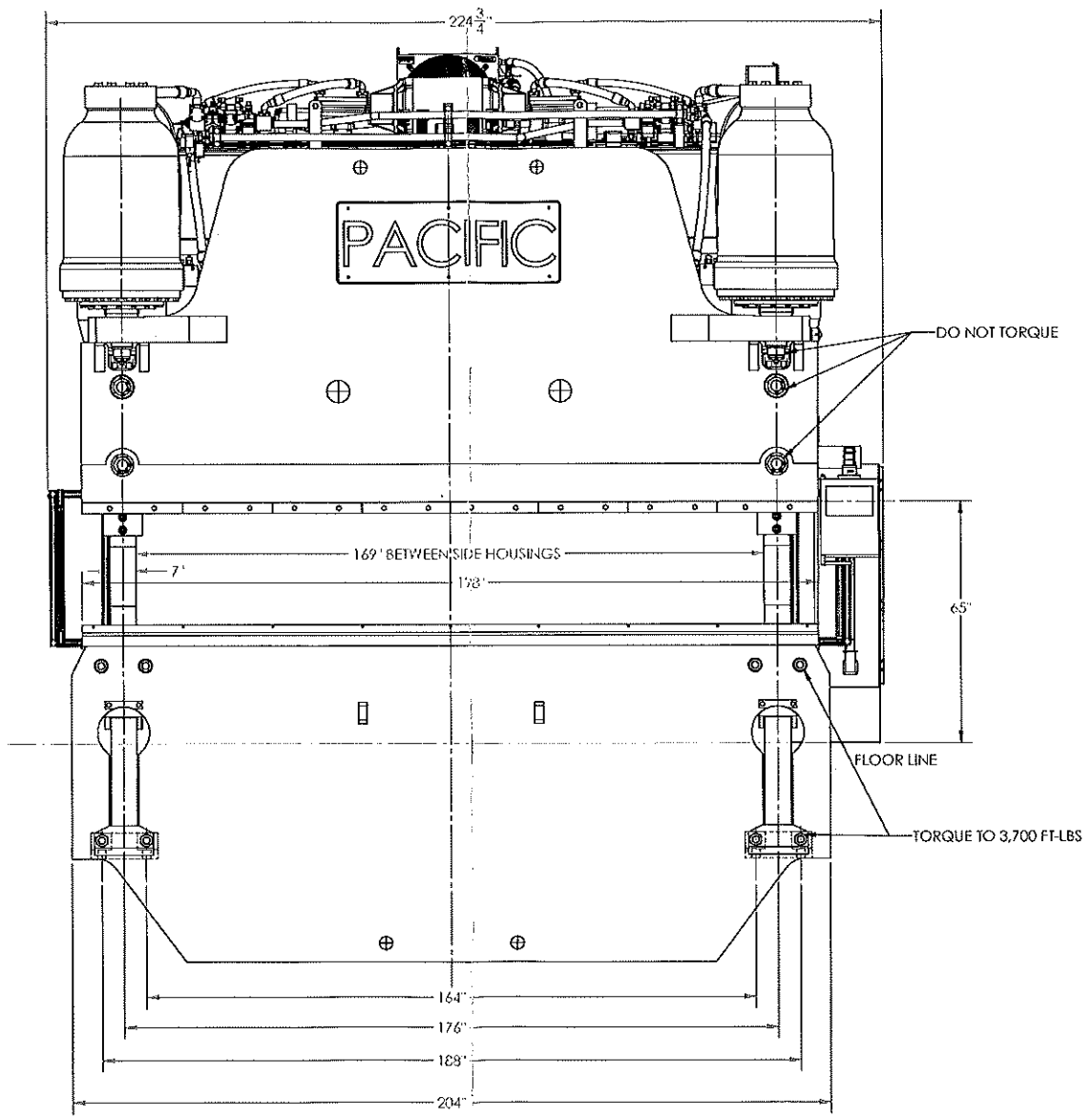
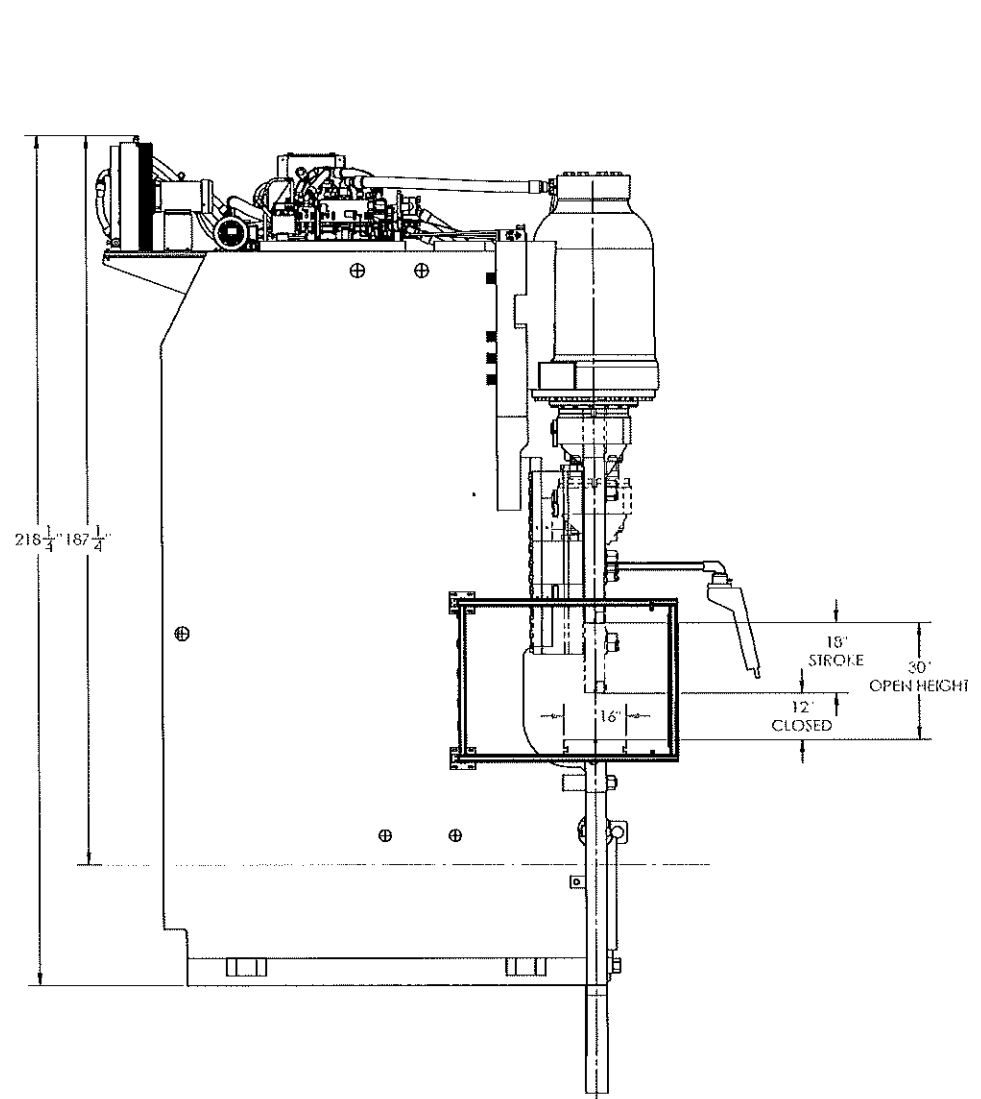

COMPONENT	EST WEIGHT (LBS)	SHIPPING DIMENSIONS
BED ASSY	30,000 LBS	17" X 91" X 204"
RAM ASSY	27,000 LBS	19" X 98" X 198"
LH SIDEHOUSING	40,000 LBS	24" X 117" X 191"
RH SIDEHOUSING	40,000 LBS	24" X 117" X 191"
LH CYLINDER	8,100 LBS	60" X 36" X 32"
RH CYLINDER	8,100 LBS	60" X 36" X 32"
POWER UNIT	5,000 LBS	60" X 36" X 32"
MISC PARTS	1,000 LBS	
<b>TOTAL</b>	<b>159,200 LBS</b>	

CUSTOMER APPROVAL  
 APPROVE  
 APPROVE WITH CHANGES LISTED  
 NOT APPROVED

SIGNATURE: \_\_\_\_\_

IT IS THE EMPLOYER'S RESPONSIBILITY TO EVALUATE EACH MANUFACTURING OPERATION TO DETERMINE AND IMPLEMENT THE BEST METHOD OF PROTECTING THE OPERATOR FROM INJURY AT THE POINT OF OPERATION IN ACCORDANCE WITH CURRENT FEDERAL, STATE AND LOCAL CODES AND STANDARDS.

USE 550 GALLONS OF HIGH QUALITY HYDRAULIC OIL HAVING A VISCOSITY OF 175 TO 230 S.U.S. AND A MINIMUM VISCOSITY OF 95. MOBIL DTE 25 MEETS THIS REQUIREMENT.

ALL DIMENSIONS TO BRACKETS UNLESS OTHERWISE SPECIFIED  
 XX +/- .01 FRACTIONAL +/- .004  
 XXX +/- .005 ANGULAR +/- .5°

ALL DIMENSIONS ARE IN INCHES UNLESS OTHERWISE SPECIFIED

THIS PRINT AND DESIGN ARE THE PROPERTY OF PACIFIC PRESS TECHNOLOGIES, AND SHALL BE KEPT CONFIDENTIAL. THIS PRINT SHALL BE RETURNED TO PACIFIC PRESS TECHNOLOGIES, WHEN REQUESTED.

**PACIFIC PRESS TECHNOLOGIES**  
 MT. CARMEL, IL

OUTLINE  
 K1250-16

DESIGNED	LWiseman	DATE	08/17/2017
CHK'D.	JC	DATE	11/15/2017
WEIGHT	241727.812 LBS	SCALE	1:24

M081292

REV.	1
OF	1

M081292